



## LUMiNODE SSR-1000

Ordering code: SSR1000

Luminode SSR-1000 switches the relay based on commands it receives over power line. It listens to commands on phase L and switches the phase Lx. The Lx can be connected to L (if you want to switch the same phase on which we are communicating) but you may also switch different phase.

### Features

- ✓ One-way powerline communication QM-50-SSI3

Parameter	Value
Input voltage	AC 220 V ~ 240 V; 50 Hz
Consumption	0,5 W
Communication interface	1-way powerline QM-50-SSI3
Max. switched power on Lx <sub>out</sub>	1000 W
Protection class	II.
IP rating	IP65
Dimensions (LxWxH)	123x70x16,5 mm
Weight	90 g
Operating ambient temperature	-30 °C ~ +70 °C
Case temperature	+80 °C
Compliance with	EN 61 347-1, EN 61 347-2-11, EN 55 015, EN 61 000-3-2, EN 61 547, EN 61 000-3-3

### Connection SSR-100 and LUMiBOX SLM-160

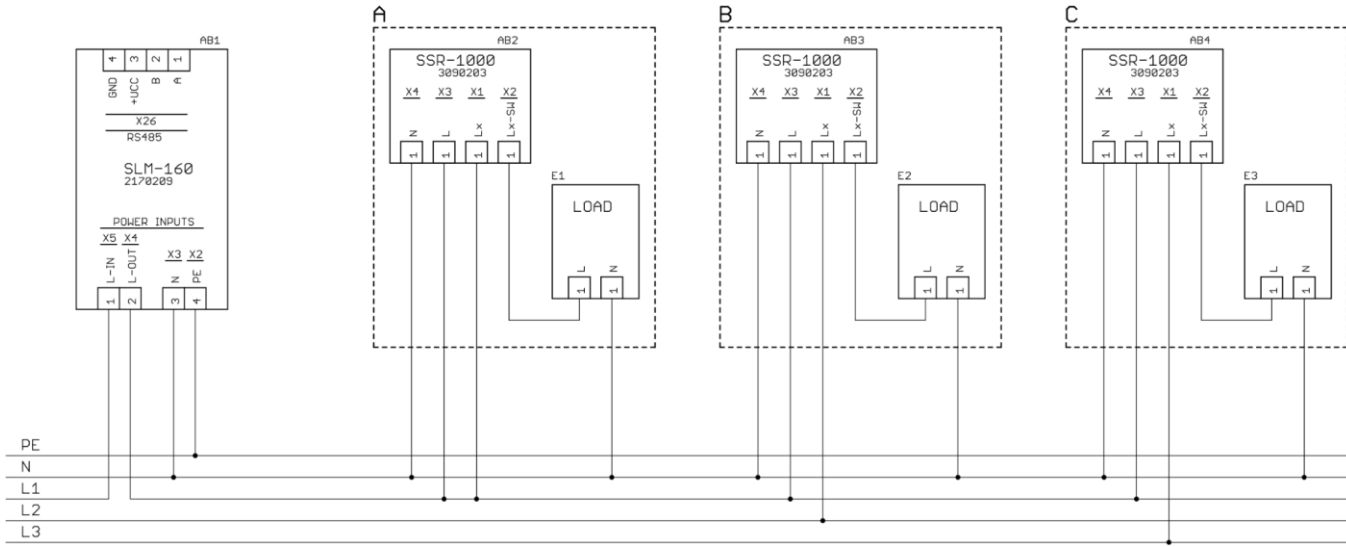

Full screen: <http://www.seakenergetics.com/files/downloads/connection-ssr-1.pdf>